

Marsh Creek Village Shopping Center

6780 Roswell Road, Atlanta, GA 30328

FOR
LEASE

Approximately ± 1,236 SF

Retail
Space



Property Highlights

- Marsh Creek Village Shopping Center
- Building "C" (downstairs) ± 1,236 SF
- Rate: \$25.00/PSF, NNN's Are \$4.50 PSF
- Both buildings built in 2010
- Great location in Sandy Springs with strong visibility and over 600 feet of frontage on Roswell Road
- Traffic Count on Roswell Road: 36,940 AADT
- Available From Approximately November 31, 2018 Forward

Daytime Population

3 mile radius: 151,376
5 mile radius: 112,146

Average Household Income

1 mile radius: \$118,979
3 mile radius: \$130,789
5 mile radius: \$143,784

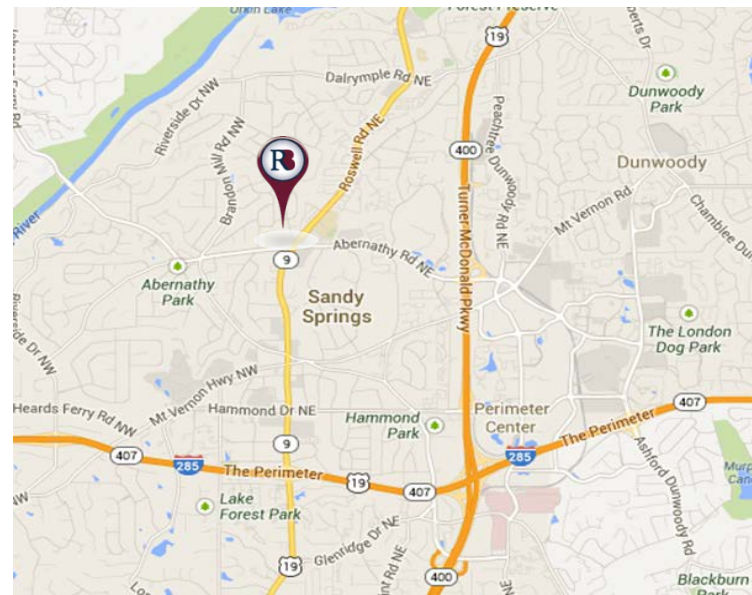

Exclusive Agents:

Jeff McMullen

Cell: 770.380.6538

jmcullen@richardbowers.com

Willie Ellington

Office: 404.816.1600 Ext 148

wellington@richardbowers.com



Richard Bowers & Co.
Real Estate



www.richardbowers.com

260 Peachtree Street, Suite 2400, Atlanta, GA 30303 | Phone (404) 816-1600 | Fax (404) 880-0077

The information contained herein has been received from sources deemed reliable but no liability is assumed by Richard Bowers & Co. or its agents for errors or omissions.

Marsh Creek Village Shopping Center

6780 Roswell Road, Atlanta, GA 30328

FOR
LEASE

Approximately ± 1,236 SF

Retail
Space

BLDG D – 1st Floor

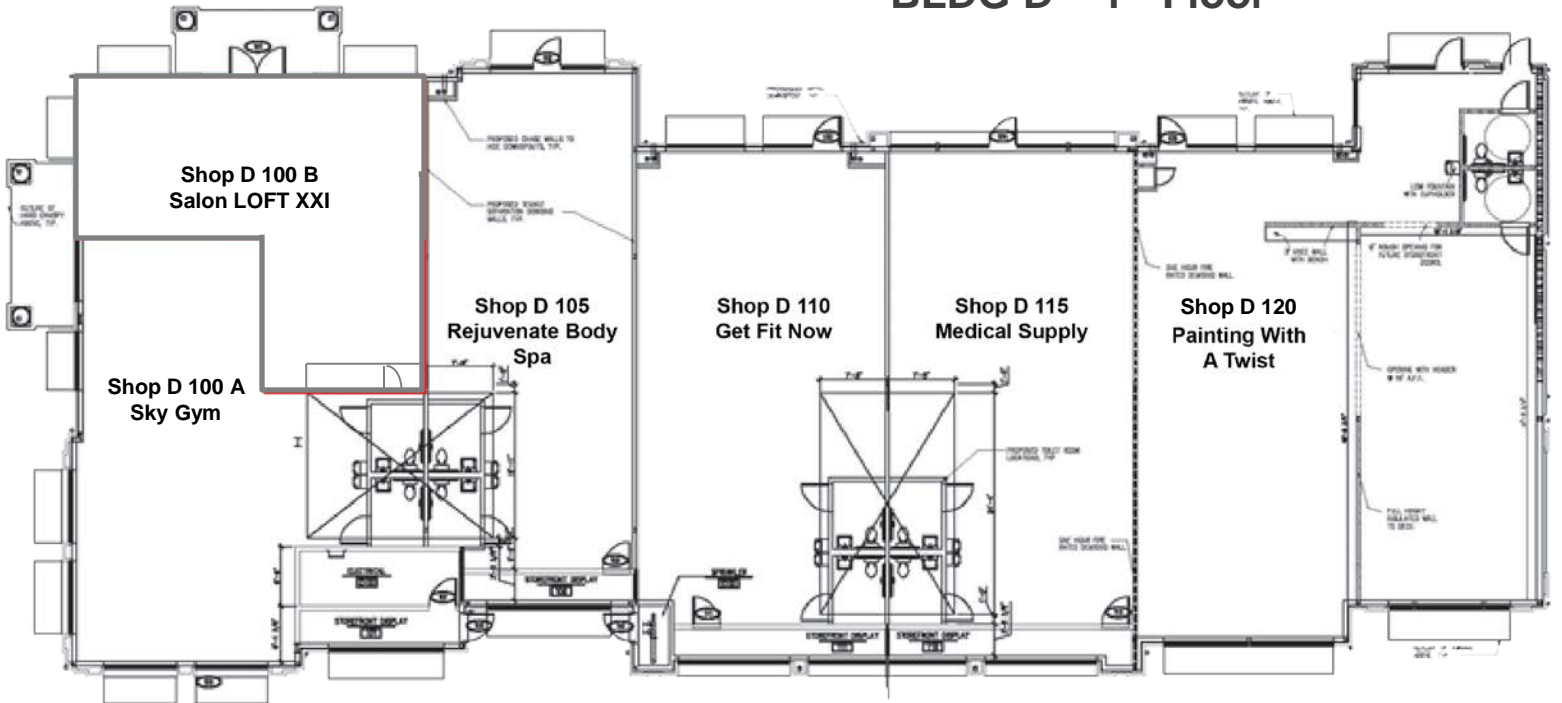

BLDG C – 1st Floor

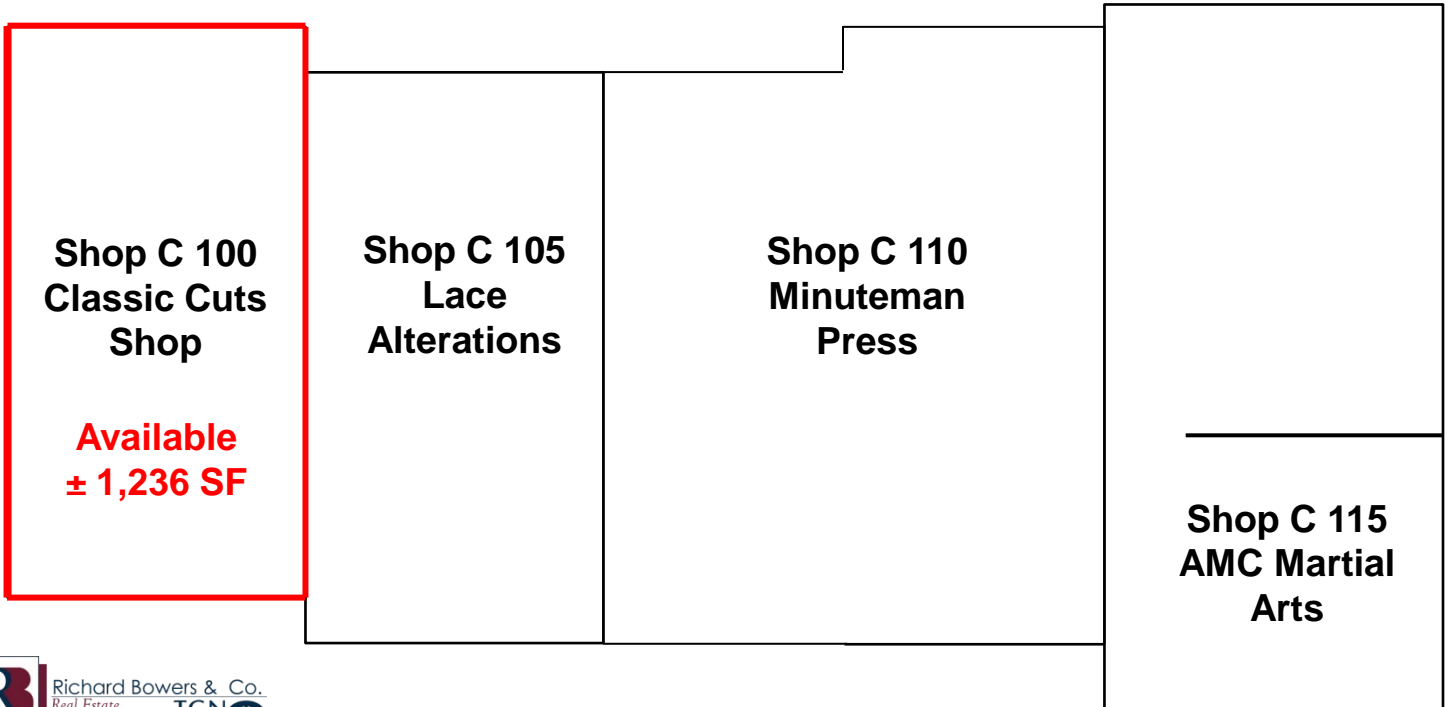

www.richardbowers.com

260 Peachtree Street, Suite 2400, Atlanta, GA 30303 | Phone (404) 816-1600 | Fax (404) 880-0077

The information contained herein has been received from sources deemed reliable but no liability is assumed by Richard Bowers & Co. or its agents for errors or omissions.